

# A NOVEL DESIGN FOR A 3.6KW LLC TRANSFORMER WITH TIGHT TOLERANCE, PRIMARY SIDE CONCENTRATED LEAKAGE INDUCTANCE

## Abstract

The benefits of the LLC topology for multi-KW On Board Charger (OBC) applications are well understood with the resonant inductor facilitating zero volt switching operation. The LLC transformer leakage inductance can replace a discrete resonant inductor if the value can be correctly sized and with the required tight tolerance. A novel construction is presented to achieve these requirements. Finite element analysis modelling (FEM) demonstrates how this leakage inductance is concentrated on the primary side for optimized performance. This analysis is validated with transformer measurement data and further verified by converter performance.

## Introduction

The system requirements, for which this 3.6KW LLC transformer was developed, include a secondary to primary turns ratio (N) of 2, a primary magnetising inductance of 36uH and a precise transformer gain of 6. It is shown that the gain is directly related to the transformer's primary winding leakage inductance, so a tight tolerance of this parasitic parameter is required for a precise gain. This paper presents a novel transformer design to achieve this. It is explained how this leakage inductance is concentrated on the primary side and confirmed by electrical verification.

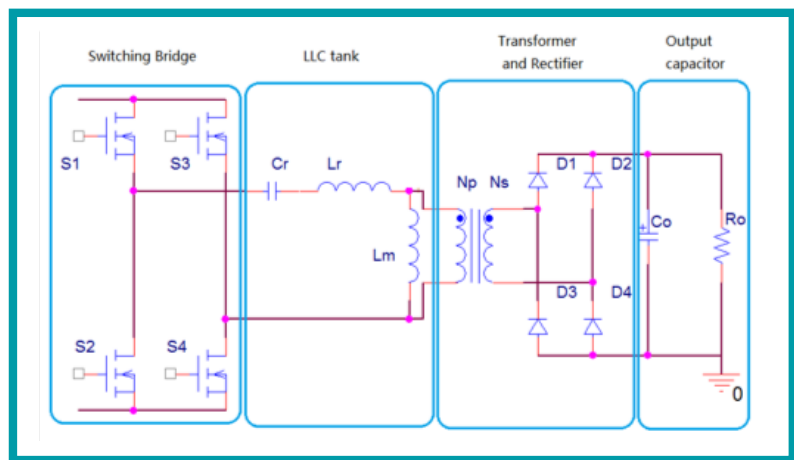

**Fig. 1: LLC Converter**

The gain of the LLC converter is defined according to the following formula:

$$(1) \quad \text{Gain} = (L_m + L_r)/L_r$$

While the tolerance of  $L_m$  can be controlled by maintaining a tight tolerance on the size of the core air gap, the resonant inductance requires further investigation.

## The LLC Converter

The reader is referred to [1] for a complete overview of the operation of the LLC converter. For the purpose of this paper, the LLC block diagram appears in Figure 1 with the resonant inductance,  $L_r$ , highlighted. This, along with the magnetising inductance,  $L_m$ , and resonant capacitance  $C_r$ , forms the LLC resonant tank that facilitates the soft switching of this topology. This feature makes the LLC the topology of choice for high-power, high-efficiency OBC solutions.

## The LLC Transformer

Figure 1 includes the ideal model for the transformer. A more complete model that includes primary and secondary winding leakage inductances and a possible external resonant inductor,  $L_{ext}$ , is presented in Figure 2 on the next page.

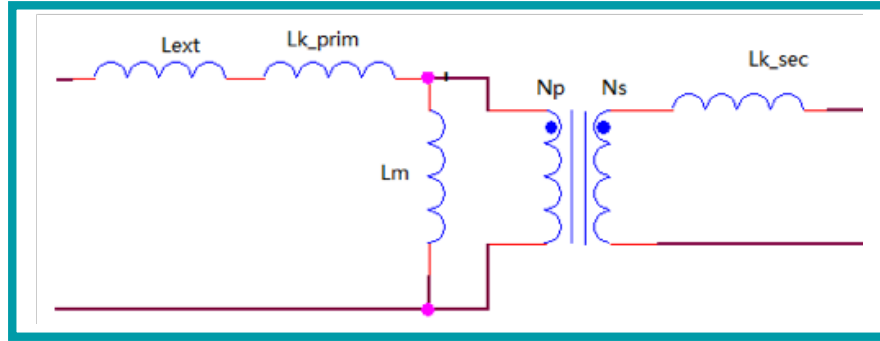
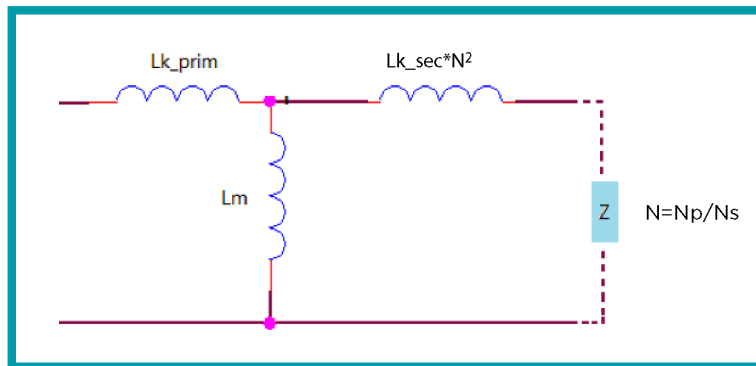

**Fig. 2: Transformer Model including leakage inductance**

The following is now apparent: (2)  $L_r = L_{ext} + L_{k\_prim}$

There is a well-established method [2] of eliminating the need for a discrete resonant inductor by designing the transformer with sufficiently high leakage inductance to meet the target value of  $L_r$ . However, a tight tolerance for such a parasitic parameter is not usually feasible. The next section of this paper presents a novel winding construction that achieves this. First, we must look at the transformer leakage inductance in more detail.

The traditional method of measuring leakage inductance of a transformer is to measure the inductance of one winding with the second winding shorted. This removes the magnetising inductance from the resultant measurement. However, as is evident by redrawing the Figure 2 transformer model with the secondary winding inductance reflected to the primary side, this measured leakage inductance includes a proportion of the secondary winding leakage inductance.



**Fig. 3: Transformer Model with primary side reflected secondary winding inductance**

Therefore, the leakage inductance measured by this method is not the actual resonant inductance. The true value of  $L_{k\_prim}$  must be determined in order to precisely define the gain. Section 5. of this paper presents a transformer design method to maximise the primary winding leakage inductance/resonance inductance and a method to precisely calculate this.

## Tuned Primary Leakage Inductance

The PQ50/50 platform and the appropriately-sized primary and secondary winding wires were selected according to the 3.6KW power requirement. Equation 2.1 defines a required leakage inductance in the range of  $6.4\mu\text{H}$  in order to meet the gain of 6. It was found that a split primary winding with sandwiched secondary winding construction approaches this target.

Figure 4 shows the winding cross-sectional area of a patented bobbin design to fine tune the leakage inductance to the correct value. The unique feature of this construction is the ability to independently control the separation between the winding segments and to reach the leakage inductance requirement. The width of each winding section and the wire bundle size is carefully selected for winding precision and, thereby, the leakage inductance tolerance is maintained.

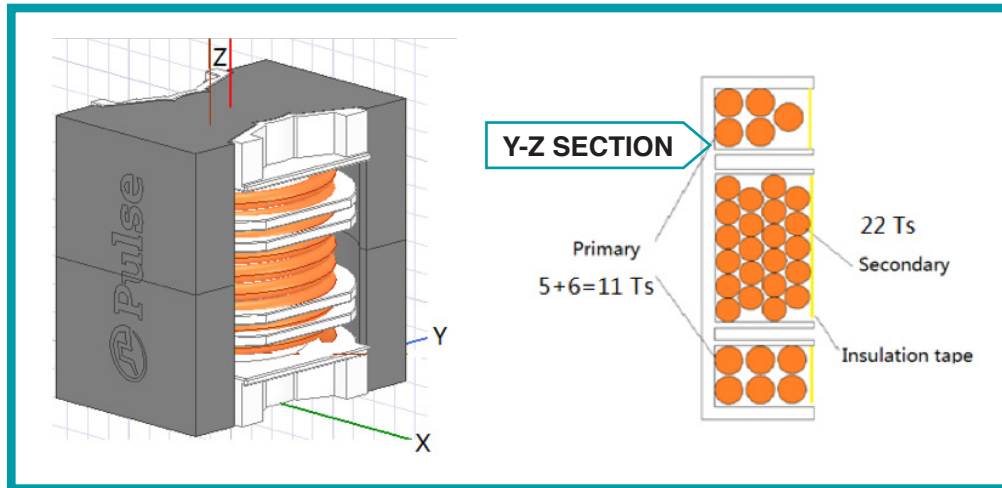

Fig. 4: Winding cross section for tight tolerance leakage inductance

## Transformer Design for Primary Winding Leakage Inductance

To complete the design so that the leakage inductance is concentrated on the primary winding, it is useful to recall that there is a leakage inductance between windings when there is incomplete linkage of the flux generated by one winding with the other winding. Conversely, if we want to minimize the secondary winding leakage inductance, then the flux generated by that winding must have good linkage with the primary winding. This is achieved with the design in Figure 5 on the right.

Figure 5 includes the equivalent magnetic model.  $R_g$  &  $R_{lk}$  is the reluctance of the air gap and the path between the windings, and  $R_p$  and  $R_m$  is the reluctance of the transformer core sections. Because the reluctance of the core material is much lower than air, that is,  $R_p$  &  $R_m \ll R_g$  &  $R_{lk}$ , we can consider  $R_p, R_m \rightarrow 0$ . Then, the magnetic model can be simplified with the primary and secondary flux flow, as shown in Figure 6 on the right.

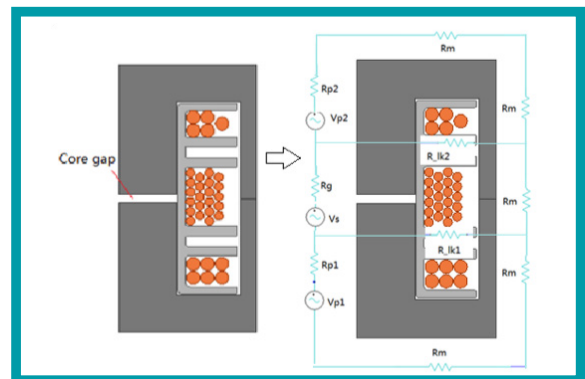

Fig. 5: Y-Z section of optimum transformer design

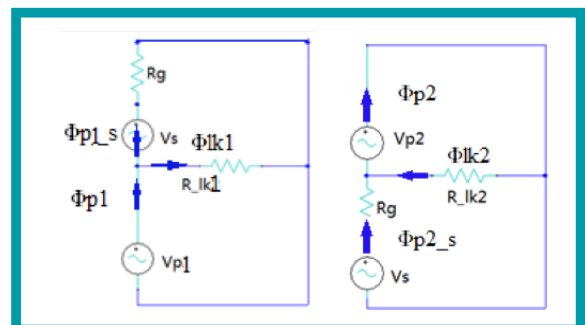

Fig 6: Magnetic model for primary flux paths

## Tuned Primary Leakage Inductance

This model shows that the location of the core air gap provides a high reluctance to the primary flux reducing the linkage with the secondary winding. However, this reluctance does not impede the secondary winding flux linking the primary winding. Figure 7 & Figure 8 show the finite element modelling of the individual flux paths.

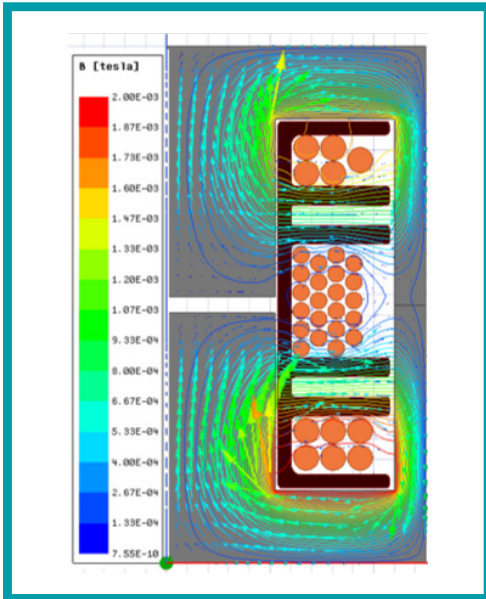

Fig 7: FEM of the primary winding flux path

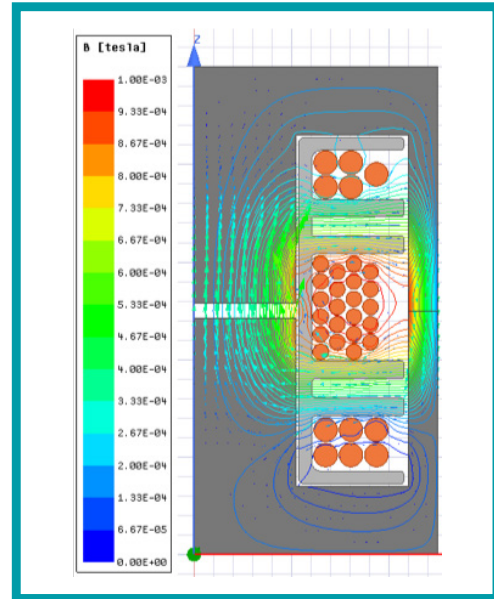

Fig. 8: FEM of the secondary winding flux path

In the next section, we validate this intuitive analysis and finite element modelling simulation of the optimized transformer design with electrical measurement.

## Experimental Validation of Transformer Design

The above transformer design was developed into prototype samples as shown in Figure 9. A measurement of the electrical parameters confirms that the target leakage inductance and tolerance was met.

To calculate the actual primary and secondary winding leakage inductances, the following transformer parameters were measured:

- Primary Inductance, Secondary Open ( $L_{so}$ )
- Primary Inductance, Secondary Shorted ( $L_{ss}$ )
- Secondary inductance, Primary Open ( $L_{po}$ )

Three equations are used to calculate the primary leakage inductance,  $L_{k\_prim}$ , the Secondary leakage inductance,  $L_{k\_sec}$ , and the magnetising inductance,  $L_m$ :

$$L_{k\_prim} = L_{so} - L_m \quad (3)$$

$$L_{k\_sec} = L_{po} - (L_m / N^2) \quad (4)$$

$$L_m = \text{SQRT}((L_{so} - L_{ss}) \times L_{po} \times N^2) \quad (5)$$

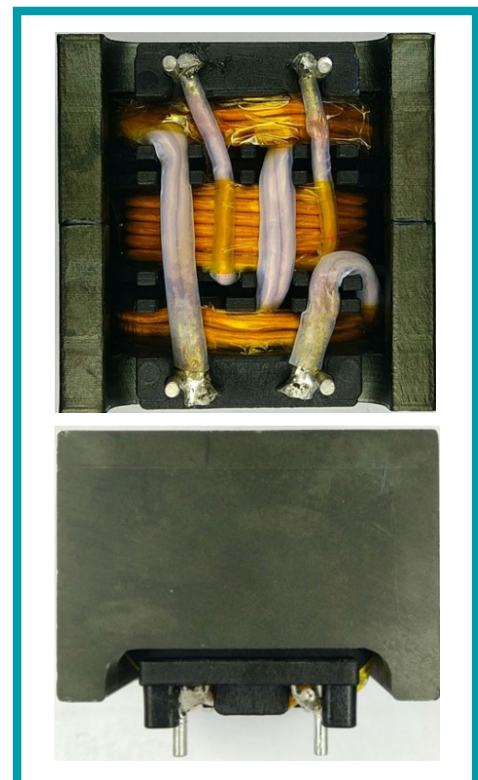

Fig. 9: Transformer prototype sample.

## Tuned Primary Leakage Inductance

Table 1 shows a summary of the transformer measurements and calculations. The target primary winding magnetising and leakage inductance parameters are well achieved, while the secondary leakage inductance is comparatively low.

**Table 1: Transformer leakage inductance**

| Lso<br>μH | LSs<br>μH | Lpo<br>μH | Lm<br>μH | Lk Pri<br>μH | Lk sec<br>μH |
|-----------|-----------|-----------|----------|--------------|--------------|
| 42.8      | 6.48      | 146       | 36.4     | 6.5          | 0.040        |

Also, it can be verified that the secondary winding leakage inductance has been effectively minimized and that the leakage inductance is concentrated on the primary side by small signal analysis. Theoretically, the winding induced in one winding of a transformer is the turns ratio times the voltage applied to the other winding, as follows:

$$V_{out} = N * V_{in} \quad (6)$$

In reality, the voltage applied to one winding is divided between the leakage inductance and magnetizing inductance according to their respective impedance. Therefore, the voltage dropped across the magnetising inductance is reduced when there is a significant leakage inductance in the winding. As a result, the voltage induced across the secondary winding will be measurably reduced. With  $N_s/N_p = 2$ , the theoretical induced voltage is:

$$V_{p\_induced} = V_{s\_applied} * 0.5 \quad (7)$$

$$V_{s\_induced} = V_{p\_applied} * 2 \quad (8)$$

The following is the induced voltage (blue) with 2V applied (yellow) across our optimized transformer secondary and primary windings, respectively.

The below results show that the induced primary voltage (1.02 V) is close to the theoretical value (i.e. half the secondary applied voltage), while the induced secondary voltage (3.52V) is significantly lower than twice the primary applied voltage. This demonstrated the concentrated nature of the primary leakage inductance.

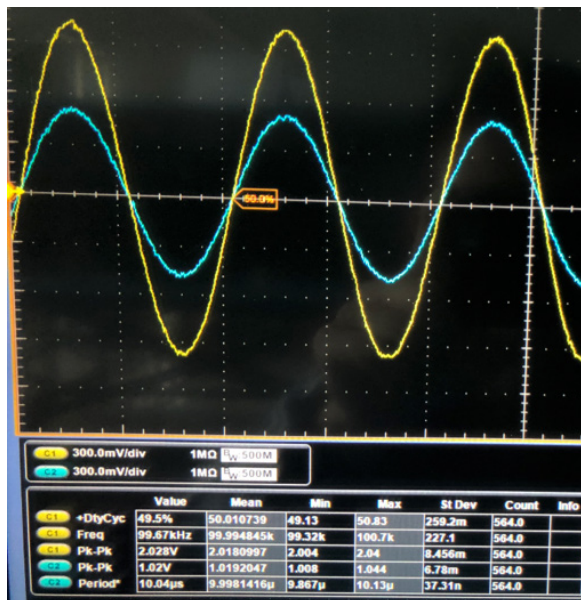

**Fig. 10: Secondary applied and primary induced voltage**

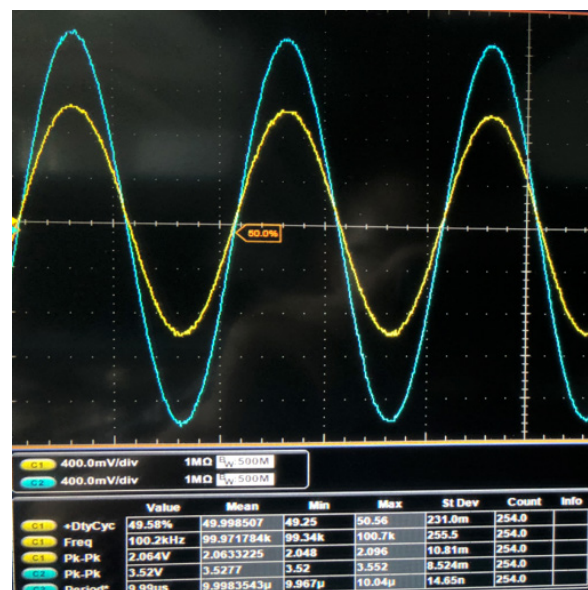

**Fig. 11: Primary applied and secondary induced voltage**

## Conclusion

This paper discusses the benefits of using the LLC topology for multi-KW, On-Board Charger applications. A novel construction is presented to show that the LLC transformer leakage inductance can replace a discrete resonant inductor.

## References

- [1] Sanjaya Maniktala, Micosemi: Understanding and using LLC Converters to Great Advantage.
- [2] S. De Simone, C. Adragna, C. Spini, STMicroelectronics: Design guidelines for magnetic integration in LLC resonant converters

Written By: Gerard Healy

Written By: Tyler Wang

SEARCH PRODUCT FINDER

GET A QUOTE

CUSTOM DESIGN SERVICES